

HOUSING



RESIDENCE HALL HANDBOOK



GRAYSON COLLEGE
STUDENT HOUSING

2023 - 2024

Vikings!

On behalf of everyone in Housing, I welcome you to Viking Nation! We're so glad you chose to make GC Housing your home: a place rich with opportunities to create lasting memories and friendships. We know how busy you are with classes, work, practices and other obligations, but we also know that you deserve a place to relax and feel at home. Grayson College is your home.

Living on campus allows you the unique opportunity to meet and interact with people from diverse and interesting backgrounds. Everyone has a story to tell, and we know being here with us at Grayson will be one of the most enriching chapters of your story. Here, you will cultivate skills and memories necessary to become the person you were always meant to be.

Our goal is to create a safe, engaging and welcoming place for you to call home. To thrive in our community, we must foster mutual respect between one another. To do this, familiarize yourself with the GC Student Handbook and the Residence Hall Handbook, which contain policies and procedures for you to write this next chapter in your life.

We know that students who reside on campus and who are involved in student life are more likely to be successful; they're also more likely to complete their academic goals. I challenge you to take advantage of these opportunities and discover the meaning of Viking Nation!

Go Vikings!

KK Patton
Housing Coordinator

Publication Note:

Although the contents of the Residence Hall Handbook were prepared on the basis of the best information available at the time of printing, the programs, policies and statements contained herein are subject to continuous review and evaluation. Grayson College reserves the right to make changes at any time without notice. If necessary, the [College website](#) will carry addendums to this publication. Grayson College is an equal opportunity institution.

Due to extenuating circumstances, including public health issues, course and testing delivery methods, instructional schedules, housing contracts, campus procedures and/or operating hours may be altered, interrupted and/or ceased for a limited or extended period of time. Such changes will be posted on the [College website](#).

ROOMING PROCEDURES

ROOM ASSIGNMENTS

Priority is given to students who lived in college housing the preceding long semester. Students will not be assigned a room until the Application and Deposit fees have been made and the background check is completed.

MOVE-IN PROCEDURES

Moving into campus housing can be an exciting and sometimes stressful experience. To make the process as easy as possible, students should plan ahead when possible and follow proper procedures.

Before receiving keys, a student must:

1. Have paid the Application and/or Deposit Fees
2. Have a completed background check on file
3. Pay down balance or be enrolled in a payment plan
4. Be enrolled in 12 credit hours or have received permission from the Dean of Student Affairs for less than full-time enrollment.

Upon arriving on campus for Move-In, a student will:

1. Check-in with Housing Staff to complete required documentation
2. Sign the Rom Contract and Meal Plan Agreement
3. Obtain room key(s)
4. Complete the Room Inventory Sheet

ROOM INVENTORY SHEETS

An inventory of the room must be completed, and the Inventory Sheet must be submitted the day the student moves in; failure to submit this form will be taken to mean the room and all articles in it are in good condition. A complete list of existing room damages, missing furniture and other irregularities is imperative. Damages and missing items not listed may be charged to you later.

ROOM CHANGES

Residents who wish to make a room change within a residence hall should contact the appropriate Housing Staff. Any resident requesting a new roommate will usually be the student required to change rooms. Residents changing rooms must follow the standard check-out procedures. Failure to follow this process may result in disciplinary action and a room fee assessment. Room changes will only be processed after the first week of classes each semester.

ROOM CONSOLIDATION

The Housing Coordinator reserves the right to make assignment and reassignment of accommodations as considered necessary. When this occurs, students will be notified in writing by the Housing Coordinator.

MOVE-OUT PROCEDURES

Check-out dates will be posted at the end of the semester. When vacating a Residence Hall, students must check out with the Supervisor and follow the proper procedures.

- Sign up for a check-out time
- Clean the room
- Remove all trash from room and bathroom
- Return key(s) to the Housing Staff
- Complete check-out paperwork
- Accompany the Staff during the room inspection

Residents must vacate the Residence Hall no later than Thursday the week of final exams, unless participating in Commencement. Other arrangements can be requested through the Housing Coordinator.

Deposit refunds will be processed within 60 days of move-out. Failure to follow these procedures will result in the student's deposit being forfeited.

MEAL PLANS

Students residing in the residence hall are required to purchase a meal plan. College food service is available in the Life Center. It is open to students, employees and guests.

Serving Hours

Days	Breakfast	Lunch	Dinner
Monday-Thursday	7:30-9am	11am-1pm	5-6:30pm
Saturday-Sunday	Closed	11:30am- 12:30pm	5-6pm

On holidays, between semesters and on other occasions when classes are not meeting and small numbers of students are present, the serving hours will be changed and/or reduced. When this occurs, the changes will be posted at the cashier's station and in the residence halls.

For the summer session, food service availability will vary.

Per Meal Rate

Students and guests may purchase meals in the dining hall on a cash basis.

Student ID Card for Residence Hall Meal Identification

The College-issued student ID card identifies the resident as a holder of a meal contract. The ID card must be shown to the cashier at each meal. Meals will not be served if the student does not present their card.

To obtain a lost or duplicate card, visit the Business Office in the Student Affairs Building to pay the replacement fee. Replacement cards are prepared in the Life Center on the 2nd floor.

Seconds

Additional servings of food, “seconds,” are typically available on all items. Please be mindful not to waste food.

Comments

Great Western Dining serves many students during the year. One of their objectives is to get to know students and their tastes. Suggestions may be made to the Food Services Director who prepares the menus which are planned to ensure daily nutritional requirements. The Food Services Director welcomes student comments at any time.

Food/Containers

All food served must be consumed in the cafeteria. Glasses, dishes and silverware may not be taken from the dining hall. Personal glasses and cups are not permitted in the dining hall due to sanitation reasons.

Dress Requirements

Students entering the cafeteria should dress in a manner that conforms to acceptable standards of good taste and cleanliness. For reasons of health and safety, shoes and shirts must be always worn.

Cafeteria Courtesies

Be respectful of others. Inappropriate or abusive language will not be tolerated. You must present your student ID to eat. Eat as much as you wish, but one entree at a time; eat what you take. Use utensils when serving yourself. Please report spills to the food services staff. Return dishes and trays to the dish room area.

CAMPUS RESOURCES

CAMPUS RESOURCES

Activities/Recreational Sports/Fitness Center

Students are encouraged to use the Life Center for recreation and relaxation. Pool tables, ping pong, a TV and comfortable sitting areas are available for student use. Entertainment, events and special activities are held throughout the Fall and Spring semesters. Details on these activities can be found on digital monitors, social media, bulletin boards and through participation in the [Student Life and Development Band](#). (Tinyurl.com/StudentLifeBand) Also, a recreational sports program is organized to give every student the opportunity to participate in supervised recreational and competitive sports activities. The Fitness Center, located in the Sports Recreation Center, is available for student use. The gym floor is not available for public use; an outdoor basketball area is available on the east side of the Jones Hall parking lot.

Career Planning and Placement

Grayson College offers students the opportunity to engage in career assessments and computerized career guidance programs in our Career Center to assist them in choosing a college major and making career decisions. The College provides career planning and job search services free of charge to students, former students, and those in the process of enrolling. The Career Center

provides opportunities for students to learn job search skills, such as resume and cover letter writing and how to interview for a job.

The Financial Aid Office is a valuable resource for work study program information.

College Police

Grayson College Police Department (GCPD) investigates all criminal incidents on campus. Officers carry firearms and make arrests independently or in cooperation with other law enforcement agencies. Residents are encouraged to contact GCPD to report any criminal activity or suspicious persons. In case of a health or safety-related emergency, officers may be reached on campus by texting or calling **903.814.3343**.

Counseling

Grayson College provides services such as personal or academic counseling. Additionally, through Grayson Cares, students are supported holistically through the Grab & Go, Vic's Market, gas vouchers and emergency student aid. The Office of Counseling and Social Services is located on the 2nd floor of the Life Center.

Student ID Cards

Student IDs are required for all Housing students. ID cards are made on the 2nd floor of the Life Center. Always keep your identification card with you. It is non-transferable; only you may use it. It is required to enter the cafeteria for each meal and for identification upon request by a Grayson College administrator, GCPD, faculty or Housing Staff.

HOUSING POLICIES AND PROCEDURES

ADDRESS & MAIL

A student who changes a permanent or local address, or name, must notify the Admissions and Records Office of this change immediately. Any communication from the College that is mailed to the name and address on record is "considered to be delivered," and the student is held responsible. Students will be informed when mail has arrived. It can be picked up from the Housing Office during regular business hours.

Address

The key items in the address to include are the name of your residence hall and the room number. To send or receive mail, please use the following information:

Viking Hall	Jones Hall
Attn: (Resident's Name)	Attn: (Resident's Name)
6101 Grayson Drive	6101 Grayson Drive
Room #	Room #
Denison, TX 75020	Denison, TX 75020

Mail

Housing Staff will collect mail each weekday and notify residents to pick it up. Students wishing to send mail may do so from the Mailroom located in the Campus Police Office. The Mailroom is open from 8am-4pm Monday through Friday (August through May). Students can purchase stamps in the College bookstore.

ANNOUNCEMENTS/ADVERTISING

General announcements concerning your residence hall activities will be posted on the bulletin boards, sent via text and/or by email. Band is also used to communicate with residence. Please subscribe by scanning the QR code on the bulletin boards. Develop the habit of checking for messages regularly. All posters advertising campus activities and events must be sponsored by recognized student organizations and. Must be approved by the Housing Coordinator. Commercial establishments and private parties cannot advertise on the bulletin boards.

Do not remove or tamper with notices posted by the Housing Staff or College administration. Notices from Grayson College's authorized personnel will be delivered to your room in order to ensure privacy and proper delivery.

APPLIANCES

Electrical appliances **allowed** in the residence halls are: computer, essential oil diffuser, stringed lights, plug-in wall fragrance, small microwave, coffee makers with K-cups, desk lamp, radio, television, clock, curlers, curling irons, clothes irons and refrigerators up to 4.5 cubic feet. Because they present health and/or safety hazards, the following are **not allowed**: open-faced electrical or heating appliances such as hot plates, broilers, electric skillets, toasters, sandwich makers, space heaters, Emerson heaters, ovens, George Foreman (and similar) grills, coffee pots with warmers, rice cookers, steamers, crockpots and halogen lamps. A fine may be assessed, and these items will be confiscated and held until the student goes home at which time they can be returned.

Microwaves and other small appliances may be made available in the common area of each residence hall. Residents are responsible for following instructions for use and cleaning after use.

CLEANING SUPPLIES

Residents must furnish their own cleaning supplies. Community items such as mops and brooms may be located in the laundry rooms.

CODE OF CONDUCT

Students are expected to always conduct themselves in an appropriate manner. The Grayson College Student Code of Conduct is in the **Student Handbook**.

COMMUNICABLE DISEASES

Important information related to communicable diseases can be found in the **Student Handbook**.

COOKING

Cooking is not permitted in the resident's room. Food must be kept in sealed containers. *Do not dispose of food through the sink, water fountain or toilet.* Plumbing repair bills will be charged to the room or hall.

COPY MACHINES & PRINTERS

Copy machines and printers are available to students in the Library. Per page charges are nominal.

DAMAGES/CHARGES

General and specific damages may include:

- Destruction of College property
- Defacing signs, walls, doors, windows, floors, trim
- Putting holes in doors, trim or walls
- Leaving stains, glue putty resident will be charged directly to the student's account

Residents are collectively responsible for maintaining the conditions of all public areas. When damages occur as a result of horseplay or vandalism that cannot be attributed to an individual, all residents may be charged through group billing. These charges are posted by the Housing Coordinator, on the bulletin board and will be updated when another charge occurs. Students are not responsible for damages caused by normal wear and tear. Registration holds may be placed on students' accounts for non-payment.

Deposits/Fees

Cleaning charges and damage charges (when applicable) will be deducted upon final check-out of the residence hall. Failure to follow proper check-out procedures could result in forfeiture of deposit. After all bills are paid to Grayson College, the deposit balance will be returned to the student, upon request, after the student has moved from the residence hall.

Fines

Failure to follow the policies and procedures of Housing may result in a fine assessment. Please find a list of fines below:

- Alcohol: \$25 per container (ie bottle, can)
- Appliances (unauthorized): \$10 (first offense); \$20 (second offense); \$30 (subsequent offenses)
- Damages: Amount will vary based on extent of damage
- Hall Meetings: \$25 per missed meeting
- Keys: \$25 (lost key card or giving key to others); \$75 (lost metal key)
- Lockout: \$10 (after first lockout)
- Moving Furniture: \$25
- Not vacating when emergency alarm sounds: \$50
- Pets: \$25 per day
- Propping Open Doors: \$50

- Smoking/Tobacco/E-Cig: \$20 (first offense); \$30 (second offense); \$40 (subsequent offenses)
- Tampering with Locks: \$25 plus cost of resulting damages
- Visitation (unauthorized): \$20 (first offense); \$30 (second offense); \$40 (subsequent offenses)

DOORS & KEYS

Exterior doors must remain closed and locked at all times. Propping open exterior doors or giving out the keys breach the safety and security of the occupants. A charge will be assessed to the violator or the residents of the hall when the violation occurs. Security cameras monitor entry and hallway activity.

Keys

Keys to the room are issued during the check-in process. If the key is lost, another key will be issued, and a replacement key fee will be charged to the student's account. Residents of Jones Hall who lose or break the white key card will be charged a fee. Report lost or broken keys to Housing Staff immediately.

Locks

Jeopardizing the security of the hall by interfering with entrance doors or tampering with a lock is a serious violation. Tampering with room door locks, such as pin locking, may be assessed a charge plus resulting in damage charges. Disciplinary probation will be imposed.

Room Door Unlock

Each resident should always keep their room key with them. After the first occurrence, a charge will be assessed each time assistance is necessary to unlock a door.

ENTRY, SEARCH & SEIZURE

Authorized staff members may enter a student's room after knocking first. Rooms will be entered in the absence of the occupant for an emergency, for health and safety checks, inventories, for maintenance or for reasonable cause. Cause is defined as a reason to believe that a rule has been broken. (For additional information, please see: FLC Local Policy – Student Rights and Responsibilities: Interrogations and Searches.)

Inspections may take place at any time without notice. Housing Staff will conduct health and safety inspections on a weekly basis. Housing retains the right to inspect closets, storage trunks and refrigerators during any health and safety inspection. Any resident found in possession of another person's personal items will be subject to disciplinary action. Students are not allowed to store items of any nature that do not belong to them. Random room inspections by authorized staff accompanied by GC Staff or independent contractors with canine units may be conducted periodically to enforce the College zero tolerance policy in reference to the unlawful possession, use, sale or distribution of narcotics, dangerous drugs and related paraphernalia on campus.

FIRE SAFETY

Fire safety and evacuation procedures will be explained at the first orientation meeting. Residence halls are equipped with a fire alarm system with several pull stations located throughout the buildings. If you discover a fire, please activate the pull station on your way out of the building. **Causing a false fire alarm is a violation of state law. Students are expected to vacate the building when an alarm sounds.** Any resident violating the policy will be assessed fines and any other penalties pending damages.

Exit Routes

Become familiar with the exit routes, which are posted at focal points in each building. Periodic emergency drills will be conducted, and students are required to participate if present. Evacuation is absolutely required when an alarm goes off.

Fire Extinguishers & Smoke Alarms

Fire extinguishers are installed all residence halls and smoke alarms in each room. These safety devices must not be disarmed, removed or maliciously discharged. A dismissed smoke alarm may result in a fine. The cost of refilling the extinguisher and for clean-up will be assessed. Additional disciplinary action could result.

Fireworks

Possession of fireworks or any explosive device(s) is prohibited by city ordinance. Possession will result in disciplinary action and damage assessments to the violator(s) or to the hall residents.

FULL-TIME STUDENT STATUS

Students living in Grayson College residence halls must maintain full-time enrollment (12 hours) each semester. Students who drop below the required 12 hours must submit an appeal to the Dean of Student Affairs.

FURNITURE

Residents are responsible for the furniture in their room. Do not remove furniture or move the furniture to another room. Furniture must not be taken apart. **Furniture must be 4ft away from the air conditioning unit.** Residents are not allowed to bring personal furniture, such as beds, couches, love seats, recliners or futons. This includes "cinder blocks" for shelving. Residents may bring televisions, tv stands or small chairs such as bean bag chairs. Should additional furniture or cinder blocks for shelving be found in the resident's room, a fine may be assessed and the student will be allotted 24 hours to remove the items from the College premises. Failure to comply will result in a Student Code of Conduct violation. The report will be submitted to the Housing Coordinator for further action.

GAMBLING

Gambling of any kind is prohibited in the residence halls and on campus.

HOUSING STAFF

The Residence Hall Staff are live-in staff members who strive to develop an atmosphere conducive to the academic and personal growth and development of residents, provide personal assistance to residents in a variety of ways and maintain a living environment which complements the needs of college students. Respect for the Housing Staff is mandatory. Rude acts of commission or omission are prohibited.

Resident Assistants support the professional staff and should be respected in the same manner.

HEALTH CARE

Grayson College provides no on-campus facilities for treatment of illness or injury. Students covered by their parents' medical insurance are advised to have a medical card should treatment be needed. In the event an emergency situation requiring immediate medical attention arises, the individual should go to the emergency room at the hospital or call 911. Report any illness or hospitalization to the Housing Office as soon as possible. Contact Housing at 903.463.8791 to request assistance due to any medical accommodations. Accommodations cannot be guaranteed without prior written notice.

HOLIDAYS

The residence halls are officially closed for semester breaks according to the Grayson College calendar. Valuable possessions should be removed from the halls during these periods to reduce the threat of theft. The College will not be liable if property is vandalized or stolen.

HOUSING HOURS

The Housing Office, located on the first floor of Viking Hall is open Monday-Friday 8am-5pm for regular business unless posted otherwise. Jones Hall residents are encouraged to use the exterior door facing the pond as an entrance.

GUESTS

Rooms and halls must be cleared of visitors at midnight on the weeknights and 2am on weekends. All visitors must be at least 17 years of age. "Visitor" is defined as anyone not assigned to that specific room or hall. Exceptions must be cleared with Housing Staff.

Visitation Hours

Days	Visitation Hours
Sunday-Thursday	10am-12am (midnight)
Friday-Saturday	10am-2am

Overnight guests

Residents may have overnight guests provided they are over the age of 17, have written consent from their room and suitemates and have the approval of the Housing Coordinator or designee. No

guests are permitted to stay overnight during finals weeks or for more than two consecutive nights. The resident is required to complete the "Overnight Guest Form" with the Housing Office three days prior to the visit of the guest. The guest is required to follow all Residence Hall policies and procedures, and the host is responsible for the conduct of their guest.

Visitation Violation Penalties

Students and their roommate if present who violate the visitation policies are subject to the following penalties:

Offense	Fine	Probation	Other Assessments
1 st Violation	\$20	None	Written Notice of Warning
2 nd Violation	\$30	Semester	None
3 rd Violation	\$40	Academic Year	Referral to Dean of Student Affairs

HOUSING CONTRACTS

Each resident must have a signed Housing Contract on file in the Housing Office. The contract covers both fall and spring semesters that the student is enrolled at Grayson College. Refer to the contract for breakage penalties.

INCIDENT REPORTS

Incident reports are cumulative as long as the student attends Grayson College. A history of incident reports will be a factor in determining the degree or type of sanction imposed. All disciplinary incidents may be recorded and transcribed for accuracy.

LAUNDRY

Laundry machines are available in the residence halls for the residents' use only. Grayson College is not responsible for laundry that is lost, damaged or stolen.

LAWS

Students are expected to comply with all local, state and federal laws and ordinances.

LIABILITIES

Grayson College is not responsible for any damage to a student's room or a student's personal effects as a result of theft, vandalism or maintenance failure. Each resident is urged to purchase renter's insurance for valuable items or possessions. The College accepts no responsibility and is not liable for theft, damage or other loss of money, valuables or personal affects or the causation of the loss.

The College is not responsible for personal property left after check-out has concluded. Grayson College will not store personal possessions; commercial storage is available in the surrounding area. Property left in the residence halls one week after check-out without permission from the Housing Coordinator shall be declared abandoned and will be discarded.

LOITERING

Residents and/or guests are requested to refrain from loitering outside the residence halls after the visitation hours have ended. Outside and inside stairs are always off limits. Stairways must be lit at night for safety.

MAINTENANCE ISSUES

Maintenance issues should be reported immediately through the online form accessed on the Housing webpage or through the QR code located on Housing bulletin boards. Maintenance personnel are on duty between 8am-2pm Monday through Friday and may not always arrive at hours most convenient to the students. Maintenance personnel will enter a room to make necessary repairs or conduct preventative maintenance even if the resident is not present. Residents are expected to cooperate with all maintenance personnel so that repairs can be made as quickly as possible.

MANDATORY HALL MEETINGS

Mandatory Residence Hall Meetings will be held throughout the semester to inform residents of important information. A fine may be assessed for missing meetings.

MISSING PERSONS POLICY

To support a resident's safety and to comply with federal law, Housing residents must provide an emergency contact.

Grayson College operates residence halls on the Main Campus to accommodate its on-campus residents. The College and residents share an equal responsibility in keeping the residence halls safe. In keeping with this responsibility, the College has adopted this Missing Persons Policy applying to all occupants of the residence halls.

Before a student may be admitted to a Grayson College residence hall, the resident must be 17 years of age- no minors are admitted to the residence halls. In addition, the student must submit a completed Housing Application, which includes the name of a contact person and how they can be contacted in the event the occupant/resident becomes missing from the residence halls. The contact information submitted is confidential and may only be released to the persons specifically identified by the resident, to administrative officials of the College who may become involved in a missing persons investigation report involving the resident and to law enforcement authorities investigating a missing person report.

A resident may be considered missing should the person be absent from the residence hall for a period exceeding 24 hours, without any apparent reason, and does not include persons who have indicated voluntary absence because of domestic, financial or similar cause. The Housing Coordinator or any other concerned person must notify a Grayson College law enforcement official once they have determined that a resident is indeed missing on an involuntary basis and after a period of 24 hours has passed.

GCPD may be contacted for the purposes of submitting a missing persons report by calling the Campus Police Department at 903.814.3343 or by contacting the Grayson County Sheriff's Office at 903.893.4388. College Policy effective May 2010 (as required by Higher Education Opportunities Act of 2009).

NOISE

Music/Loud Noise

After two warnings about loud music, excessive volume on stereo/computer equipment and/or boisterous behavior, a resident's use of the equipment that contributes to the loud noise may be restricted for a set time. Continued offenses may require that the equipment be taken home for the remainder of the semester. Loud music may not be played during quiet hours. Volume on music played from cars on campus should be low.

Quiet Hours

Residents should always be aware of others' sensitivity to noise. Doors should remain closed. Consideration of sleep and study times should be observed, especially with regard to noise (ie music, tv, screaming, etc.). Any noise that can be heard outside a resident's room or which disturbs others is a violation of Quiet Hours. Quiet hours begin at 10pm Sunday-Thursday and 12am Friday-Saturday. Residents should not congregate in the hallways during Quiet Hours. During final exams, Quiet Hours are in effect 24/7. The lounge should be used as an individual/group study hall.

While Quiet Hours are during set periods of time, Courtesy Hours are 24/7. This means there should be no excess noise at any given time in the residence halls. Residents should always be aware of their noise level and should be courteous of their roommates and neighbors.

PARKING

Vehicles must display a valid parking sticker in the designated space. Do not park in a reserved, visitor or handicapped space unless eligible. Tickets will be issued, and fines must be paid. Cars may be towed from these spaces.

PET POLICY

Students are not allowed pets other than pre-approved Emotional Support/ Service Animals or small fish. If fish are kept in the residence halls, they can be no larger than a 3-inches kept in no larger than a 1-gallon bowl. Fish that are dangerous or harmful to humans and are prohibited by state or federal laws are not allowed.

Students who choose to have fish are required to properly always care for their fish, including making arrangements for their care during breaks, travel, etc. Students who plan to house fish in their rooms are expected to keep the tank clean and sanitary. If a fish should die while in the residence halls the student should properly dispose of the remains; residents should not flush fish down the toilet. If a fishbowl breaks, the resident is required to clean all of the resulting water and other mess from the bowl. Any water damage is the responsibility of the student.

Suggested fish:

- Betta Fish
- Endler Guppies
- Ember Tetras
- Zebra Danios
- White Cloud Minnows

A fee will be assessed for unregistered animals. Please see Service/Comfort Animal Policy for approved animals and procedures.

PHYSICAL ALTERCATIONS

Physical altercation (fighting) is a major violation of the Grayson College Student Code of Conduct and will not be tolerated. Students who violate this section of the code as published in the Student Handbook may be subject to suspension from the residence hall and/or College. Residents may report assaults or suspicious behavior to Housing Staff, Campus Police or any member of the College staff.

PHYSICAL FITNESS & RECREATION EQUIPMENT

The use of physical fitness equipment (ie exercise benches, treadmills, electrical equipment, etc.) is prohibited. **Weights are not permitted in the rooms.**

Dart boards are not permitted inside the residence halls. The possession or use of BB guns, pellet guns/Airsoft guns, paintball guns, water guns or slingshots is prohibited. Also, baseballs, basketballs, bats, golf balls/clubs, softballs, volleyballs and similar items are not to be bounced, thrown or swung inside the residence halls. Roller blades or skateboards may not be used in the hallways or on campus walkways.

PROFANITY

Grayson College specifically prohibits the use of profanity and obscenity on college-owned property or at college-sponsored events. Use of such profanity and obscenity may result in one or more disciplinary measures being taken, ranging from a warning to a fine.

ROOM APPEARANCE

Rooms must be kept clean and orderly. Empty wastebaskets regularly. Trash must be disposed of neatly in the trashcans located in each hall. When you sweep your room, don't leave excessive residue in the hallways. Do not leave bags of trash in the hallways, laundry rooms or bathrooms. Keep dirty clothes in laundry containers.

Room inspection will be conducted periodically. When a room does not pass inspection, a warning will be given. Residents will have 24 hours to address the expressed concerns. Failure to comply could result in a fine.

Room Decorations/Walls

Residents are allowed to decorate their rooms. Plants, posters and pictures are allowed. Students are not permitted to write or paint on doors or walls. Pictures and posters should not be indecent and should not cover more than 20% of the wall space. No screws, nails or bolts are allowed in the room walls, ceilings or floors. Poster putty, Command strips or painter's tape must be used for securing items to the walls in all rooms. To avoid damage, when using Command strips, place painter's tape on the wall first and then the Command strip on top of it. Use only poster putty that is clean and unused. Poster putty must be completely removed from the walls upon check-out. The use of double-sided tape, nails, thumbtacks, etc. will result in a damage assessment. Charges for violations as well as repairs will be assessed.

- Candles, extension cords, decorative or scented incense or wax melters are not allowed in the rooms because they are a potential fire hazard. They will be confiscated and a fine assessed.
- Wall Flowers and other plug-in fragrances are permitted if they are unobstructed.
- Do not attach anything to the ceiling.

SEX-BASED HARRASSMENT

Campus policies related to sex-based harassment are found on the College website. Use the search feature to quickly locate the [Policies and Procedures Manual](#) (Section F - Students). Violations of these policies may be reported to a Resident Advisor, Housing Staff or other college employee. You may also visit with the Title IX Coordinator, Dr. Molly Harris, for additional information.

SMOKING, SMOKELESS TOBACCO & ELECTRONIC SMOKING DEVICES

All buildings on the Grayson College campus have been declared tobacco free. Tobacco is permitted only in designated areas and parking lots, at least 20 feet from a building entrance. For additional information, please see GDA Local Policy - Tobacco and E-cigarettes.

SOLICITING

No soliciting or selling is allowed in the residence halls without prior permission from the Dean of Student Affairs.

STUDENT COMMUNICATION

Students are required to use their Canvas account or student-issued Viking email for all electronic communication. To ensure the identity of the student communicating electronically, GC faculty and staff will not reply to student communication sent through an account other than Viking email or Canvas account.

STUDENT COMPLAINTS

Refer to the Student Handbook for information on filing a complaint.

TELEPHONES & LONG DISTANCE

Viking Hall Only- Individual rooms are wired for telephone service. Residents wanting phone service must contract with a local telephone company to establish service and make arrangements to be present for installation. The College is not responsible for repair to phone lines in the residence halls.

TELEVISION, CABLE & VIDEOS

A television is available in the lobby of each Residence Hall. Individual rooms in Viking Hall are wired for cable service. Cable service must be secured from the local cable company. Individual satellite systems are prohibited.

VENDING MACHINES

Vending machines are available in the residence halls. If money is lost in a vending machine, the resident should report the loss to the Housing Coordinator. Refunds are issued in the Business Office. Tampering with and damage to the vending machines will necessitate their removal from the residence halls.

WATER BALLOONS

Water balloons are not allowed. Water balloons and fights are a punishable offense.

WEAPONS

Campus Carry

Grayson College is committed to providing a safe environment for students, faculty, staff and visitors, and to respecting the right of individuals who are licensed to carry a handgun where permitted by law. Please note: persons must be at least 21 years old to legally carry a handgun. Handguns must be properly secured when not on the licensed carrier's person. Additionally, open carry is *not* permitted. The College is further committed to developing and implementing Concealed Campus Carry Regulations that are in compliance with Texas Law to include Texas Government Code Section 411.2031 (Carrying of Handguns by License Holders on Certain Campuses) and Texas Penal Code 46.035 (Unlawful Carrying of Handgun by License Holder). For more details, see the [Campus Carry FAQ](#) on the College's website.

Labor Code 52.063

A licensed holder may carry a concealed handgun on or about the license holder's person while the license holder is on the campus of an institution of higher education or private or independent institution of higher education in this state. *Gov't Code 441.2031(b)*

Weapons

A person commits an offense if, with a knife, club or prohibited weapon, they intentionally, knowingly or recklessly go onto the physical premises of a school or education institution. For more information, contact Grayson College Police Department.

WELFARE OF STUDENTS

When situations exist that threaten the welfare of students, the Dean of Student Affairs will assume responsibility for conducting a thorough review, based upon the best medical and/or legal information available. Any action taken will respect the confidentiality of the individual as well as the individual's welfare and that of the College community. The College may consider suspending, expelling, quarantining or otherwise disciplining students who fail to heed counseling and engage in conduct known likely to infect or harm others.

HOUSING RULES AND REGULATIONS

The following rules and regulations are for the protection of the rights, health and welfare of all residents. Each resident is accountable as an adult and is responsible for their room. Each resident is responsible for ensuring the rules are always followed and should recognize that these are the major rules and thus the list of rules is not all-inclusive. Infractions of these rules may result in probation or suspension from the residence halls. The Dean of Student Affairs will guarantee due process to all residents.

BEHAVIORS THAT MAY RESULT IN SUSPENSION

* For a specified period; ** permanent

1. All persons possessing, drinking, using intoxicants or narcotics, in or around persons involved with these items in College buildings or parking lots may be issued a citation and/or Housing fine and may be subject to arrest. **
2. Visitors are only allowed in the residence halls during visitation hours. Any non-resident in the halls before or after will be considered an unauthorized visitor and is subject to a citation, arrest or student disciplinary action. Overnight guests are permitted only with proper approval. **
3. Carrying or being in possession of illegal firearms, fireworks or any type of weapon prohibited by law or lethal in nature, initiating a false fire alarm, which is a state offense, may be issued a criminal citation and/or jail time. **
4. Violation of municipal, state or federal law on College property. **
5. Physical altercations. **

BEHAVIORS THAT MAY RESULT IN PROBATION OR REFERRAL TO DEAN

* For a specified period; ** permanent

1. Smoking or use of tobacco products anywhere in the residence halls. *
2. Noise of a disturbing or disruptive nature; loud music of any kind. (Coming in quietly is expected. Quiet and Courtesy Hours will be enforced.) *

OTHER RULES

1. The resident who invites a visitor or who admits an unidentified visitor into the residence hall is responsible for the behavior of the visitor/unidentified person.
2. Visitation times in the residence hall may vary according to the semester. Please see the visitation rules and check with the Housing Staff or the Residence Hall Handbook for times.
3. Only pre-approved overnight visitors are allowed. The resident is required to complete the "Overnight Guest Form" with the Housing Office three days prior to the visit of the guest. The guest is required to follow all Residence Hall policies and procedures, and the host is responsible for the conduct of their guest.
4. All visitors must be at least 17 years of age. "Visitor" is defined as anyone not assigned to that specific room or hall. Exceptions must be cleared with Housing Staff.
5. Collecting beer cans or other alcoholic beverage containers and street signs is prohibited.
6. A fee will be assessed for unregistered animals. Please see Service/Comfort Animal Policy for approved animals.
7. Use of a water hose and washing of vehicles are not allowed in the parking lots.
8. Collecting or burning incense or candles is strictly prohibited.

FOR YOUR INFORMATION

1. The Housing Staff checks all rooms for damages and cleanliness prior to entrance, during occupancy and upon check-out. Room checks or room searches can be done for cleanliness. Random room and hall searches may be conducted or if reasonable suspicion exists to do so.
2. There is a charge for lost keys (see Doors & Keys regarding keys).
3. Residents will be charged for theft and/or damage caused by them or their visitors anywhere in the residence halls.
4. Refund of deposit will be determined upon check-out.

HOW DO I KNOW HOW MY ANIMAL IS CLASSIFIED?

Service Dogs:

A dog individually trained to do work or perform tasks for the benefit of a disability is a service animal.

- Recognized by the ADA (It is the handler's right to have the dog provide a service).
- Can go everywhere handler goes; trained to respond to handler's needs.
- The use of this animal on campus does not prompt registration with Accessibility Services or College Housing.

Emotional Support Animal:

A dog/cat not trained to respond to any stimuli, animal's presence is its value is an assistance/emotional support animal.

- Covered under the Fair Housing Act (not recognized by ADA because there is no right to comfort).
- Animal's presence as support, well-being, or comfort does not constitute work or tasks.
- The use of this animal in Housing must be approved through both Accessibility Services and College Housing.

Service Dogs in Training:

A dog you are training to perform a task for the benefit of a disability dog must be accompanied by approved trainer at all times is a service animal in training.

- ADA recognizes one's ability to train their own animal. However, the ADA does not recognize a service animal in training as a service dog and does not allow the same access.
- Texas Law allows for Service Animals in Training but must be always accompanied by approved handler.
- The use of this animal on campus must be approved through Accessibility Services.
- If student is the approved (certified) trainer, then documentation stating such must be provided to Accessibility Services. If student is NOT approved trainer, student and service dog in training must be accompanied by approved trainer at all times.

STATE OF TEXAS HUMAN RESOURCE CODE

TITLE 8. RIGHTS AND RESPONSIBILITIES OF PERSONS WITH DISABILITIES SEC. 121.005.

RESPONSIBILITIES OF PERSONS WITH DISABILITIES

- A. A person with a disability who uses an assistance animal for assistance in travel is liable for any damages done to the premises or facilities by the animal.
- B. A person with a disability who uses an assistance animal for assistance in travel or auditory awareness shall keep the animal properly harnessed or leashed, and a person who is injured by the animal because of the failure of a person with a disability to properly harness or leash the animal is entitled to maintain a cause of action for damages in a court of competent jurisdiction under the same law applicable to other causes brought for the redress of injuries caused by animals.

SEC. 121.006. PENALTIES FOR IMPROPER USE OF ASSISTANCE ANIMALS

1. A person who uses a service animal with a harness or leash of the type commonly used by persons with disabilities who use trained animals, in order to represent that his or her animal is a specially trained service animal when training has not in fact been provided, is guilty of a misdemeanor and on conviction shall be punished by:
 1. a fine of not more than \$300; and
 2. 30 hours of community service to be performed for a governmental entity or nonprofit organization that primarily serves persons with visual impairments or other disabilities, or for another entity or organization at the discretion of the court, to be completed in not more than one year.
2. A person who habitually abuses or neglects to feed or otherwise neglects to properly care for his or her assistance animal is subject to seizure of the animal under Subchapter B, Chapter 821, Health and Safety Code.

HOUSING SERVICE AND ASSISTANCE ANIMAL PROCEDURES

All assistance animal requests (service animal in training or emotional support animal) must be submitted to the Accessibility Services (AS) office located in the Student Success Building for approval. Students with service animals should read and familiarize themselves with the following procedures.

With exception to a fish, no animal will be permitted in residence halls that:

- Is not approved by the AS office (Assistance Animals)
- Poses a direct threat to the health or safety of others
- Would cause a substantial physical damage to the property of the College and other residents
- Would pose an undue financial and administrative burden to the College
- Would fundamentally alter the nature of the College's housing operations

STANDARDS FOR SERVICE OR EMOTIONAL SUPPORT ANIMALS

All service or approved assistance animals must comply with applicable laws regarding animals, including Chapter 4 – Animals in the City of Denison Code of Ordinances, their treatment and care, and must also meet the following standards:

Dogs (Service and Assistance Animals)

- All required immunizations must be up-to-date and a copy of the immunizations must be on file with the Office of Accessibility Services.
- Dogs must be licensed and a copy of the license must be on file with AS.
- Dogs must be spayed or neutered. A copy of the veterinarian's report must be on file with AS.
- A Certificate of Health signed by a veterinarian certifying the dog is healthy and free from any signs of infectious or contagious diseases, parasites, etc. must be on file with AS.

- Collars and tags must be worn at all times. The dog must be kept on a leash at all times when outside the residence hall or apartment. Dogs must never be allowed to run freely.
- Dogs must possess friendly and sociable characteristics. A specific dog can be restricted from the premises by AS or designee based on any confirmed threatening or territorial behavior. Dogs that are classified as "Dangerous Dogs" (*Texas Health and Safety Code Title 10., Chapter 833, Subchapter A, Sec. 822.041*) and "Dangerous Dogs" (*Denison City Ordinance, Chapter 4, Article II. Sec. 4-39*)
- Service animals in training are permitted with certified trainers.
- Dog obedience and training programs are highly recommended.

Domestic Cats (Assistance Animals Only)

- All required immunizations must be up-to-date and a copy of the immunizations must be on file with AS.
- Cats must be licensed and a copy of the license must be on file with AS.
- Cats must be spayed or neutered. A copy of the veterinarian's report must be on file with AS.
- A Certificate of Health signed by a veterinarian certifying the cat is healthy and free from any signs of infectious or contagious diseases, parasites, etc. must be on file with AS.
- Collars and tags must be worn at all times. The cat must be kept on a leash at all times when outside the residence hall or apartment. Cats must never be allowed to run freely.

Any Other Animal

To be considered on a case-by-case basis by the Housing Coordinator or designee. Animals defined as "Dangerous Wild Animals" in the Texas Health and Safety Code §822.101 (big cats, apes, bears, hybrids of these animals), primates, high rabies risk animals (bats, fox, raccoon, coyote) venomous animals and domestic animals with unknown health history are not allowed.

STANDARDS OF BEHAVIOR BY ANIMAL AND ANIMAL OWNER

Health, sanitary, safety, and disruptive standards must be maintained as follows:

- The student must have an already established relationship with the animal (Emotional Support Animals).
- Animals require daily food and attention, as well as a daily assessment of their general health, behavior and overall welfare.
- Animals cannot be left unattended overnight at any time. If the owner must be away, they must either take the animal with them, or make arrangements for them to be cared for elsewhere, which does not include other residence hall spaces.
- In shared living spaces, the animal must be in an appropriate container if the owner is not in the room with the animal.
- Emotional support animals must not be taken into the residence hall offices, administrative offices, common space or student living areas.
- Animal waste must be taken care of and any animal handler or owner must comply with Denison City Ordinance Chapter 4 Article I. Sec. 4-1. Animal feces, defined as cat litter box contents and any solid animal waste, must be disposed of properly. It is the owner's responsibility to remove feces from College grounds, dispose of it in a plastic bag, and then

place that bag in the garbage dumpsters outside. Cleanup must occur IMMEDIATELY. Animal feces may not be disposed of in any trash receptacle or through the sewer system inside any building on the Grayson College campus. Waste MUST be taken to any residence hall dumpster for disposal.

- Residents with cats must properly maintain litter boxes. In consideration of the health of the cat and occupants of the residence hall room, cat litter box contents must be disposed of properly and regularly. The litter box must be changed with new cat litter regularly as outlined by the manufacturer.
- Animal-accidents within the residence hall room must be promptly cleaned up using appropriate cleaning products.
- Regular and routine cleaning of floors, kennels, cages, and litter boxes must occur. The odor of an animal emanating from the residence hall room is not acceptable. (see Cleaning Section below)
- Any flea infestation must be attended to promptly by the Housing Coordinator contracted professional extermination company at owner's expense. Owners are expected to promptly notify the dorm office or the Housing Coordinator facilities staff and arrange for extermination when a flea problem is noted. Animal owners may take some precautionary measures such as: flea medications prescribed by veterinarians, flea and tick collars, taking the animal to the veterinarian for flea and tick baths.
- Animals must not be allowed to disrupt others (e.g., barking continuously, growling, yowling, howling, etc.). Animals which constitute a threat or nuisance to staff, residents or property, as determined by the Dean of Student Affairs or designee, must be removed within seven (7) days of notification. If Grayson College Police Department personnel determine an animal poses an immediate threat, animal control may be summoned to remove the animal. If the behavior of an animal can be addressed by the owner and the owner can change the behavior of an animal so the animal does not have to be removed, then a written action plan must be submitted by the owner. The action plan must outline the action to take place to alleviate the problems and must give a deadline as to length of time the plan will take to complete. Any action plan must meet the approval of the Dean of Student Affairs or designee. The day after the deadline for removal from the residence hall, Housing Coordinator or designee will do a residence hall room inspection to check damages and infestation and then the mandatory cleaning and extermination will be scheduled. Any animal owner found not adhering to the removal directive will be subject to disciplinary action, which could include contract cancellation.
- An animal must not be involved in an incident where a person experiences either the threat of or an actual injury as a result of the animal's behavior. The animal owner will take all reasonable precautions to protect college staff and residents, as well as the property of the college and of the residents.
- The owner will notify residence life staff via the hall office if the animal has escaped its confines and is unable to be located within eight (8) hours.
- All liability for the actions of the animal (bites, scratches, etc.) is the responsibility of the owner. Violations concerning any of the aforementioned may result in the resident having to find alternative housing off campus for the animal and, as warranted, may also result in a resident being in breach of their housing contract.

- The owner must notify the Accessibility Services Office if the animal is no longer needed or is no longer residing on Grayson College property. If the animal will be replaced, the owner must submit a new request.

Cleaning and Damages

When a student moves out of their residence hall room, or no longer owns the animal, the residence hall room will be assessed to determine if damage to College property can be attributed to the animal. Housing maintains the right to conduct residence hall room inspections as needed for the purpose of assessing damage caused by the animal or otherwise determine the resident's compliance with this procedure.

- The animal owner has an obligation to make sure that the residence hall room is as clean as the original standard. If the room has carpeting, this also includes regular vacuuming and spot cleaning. Damages and extraordinary cleaning caused by the animal are the responsibility of the resident. Replacement or repair of damaged items will be the financial responsibility of the owner and assessed by the Housing Coordinator.

SERVICE AND ASSISTANCE ANIMAL PROCEDURE ACKNOWLEDGEMENT

The Accessibility Services Coordinator, Dean of Student Affairs and student will sign the Service and Assistance Animal Procedure Acknowledgement Form. This form is available online through the Grayson College Accessibility Services Office on the Main Campus. (903.463.8751)

SERVICE ANIMALS IN TRAINING

ADA Service Animal Terms

The Service Animal FAQ document (ada.gov/resources/service-animals-faqs/) published by the Office of Civil Rights addresses two key points:

1. The ADA does not require service animals to be professionally trained. People with disabilities have the right to train the dog themselves and are not required to use a professional service dog training program.
2. HOWEVER, service-animals-in-training are not considered service animals. Under the ADA, the dog must already be trained before it can be taken into public places. Thus, until the training is complete, the service animal in training does not have the same protection and privileges as a fully trained service animal. Some State or local laws cover animals that are still in training. The State of Texas does recognize Service Animals in Training to have access to the same areas as trained service animals as long as they are accompanied by an approved trainer. Grayson College requires the student provide documentation of their certification as the trainer from an approved organization. State of Texas Code Sec.121.003 (i) A service animal in training shall not be denied admittance to any public facility when accompanied by an approved trainer.

Requirements for Students:

1. Complete the Accessibility Services Verification Form for Service Animals in Training. This form does not register the student with AS for classroom accommodations, but if the student

wants to apply for services, they can do so. This AS Verification Form, along with documentation certifying the student as an approved trainer (#2), will be kept on file in the AS Office.

2. Provide AS a certification of training document. An approved trainer recognized by Grayson College is an individual who has been certified by an organization whose primary mission is to train service animals for people with disabilities. If the student is not an approved trainer, the student must provide proof an approved trainer will be with the student and the dog while in campus buildings.
3. Meet with Accessibility Services Coordinator to obtain approval for bringing a Service Animal in Training into campus buildings. A campus building is any building on campus, including housing facilities. During this meeting, AS Coordinator and student will:
 - a. Review published ADA language that allows for the person to train the dog themselves but does not recognize service animals in training as a protected accommodation.
 - b. Review State of Texas statute that does allow service animals in training to access the same areas as Service Animals as long as they are accompanied by an approved trainer.
 - c. Review GC's policy on what constitutes a recognized approved trainer.
 - d. Review GC's policy that Service Animals in Training must be identified by a vest or tag indicating they are in training and must comply with and abide by the same college policies and procedures that any Service Animal or Assistance Animal follows. This includes policies within the Code of Student Conduct.
4. Housing Requirements – If the student resides in GC Student Housing, the Verification Form will be sent to the Dean of Student Affairs as well.

Service Animals in Training Verification Form

This form is available online through the Grayson College Accessibility Services Office on the Main Campus. (903.463.8751)

HEALTH GUIDELINES

COVID-19 GUIDELINES

Should the need arise, specific Covid-19 guidelines will be put into place. Depending on College guidelines, the following safety precautions may be implemented. Due to the evolving nature of the Coronavirus, guidelines may be changed based on College, state, local and federal recommendations and/or mandates.

- Guests are not permitted in the residence halls.
- Face coverings must be worn at all times. The only exception is when students are in their rooms.
- Students must practice social distancing while in common spaces (ie study rooms, lounges, lobbies, cafeteria).
- Students are expected to conduct routine cleaning of personal bathrooms, which will be checked frequently.

- To allow for social distancing, there is a 2-person limit in the elevators. When possible, use stairs rather than sharing an elevator.
- Follow seating guidelines in common spaces (do not move furniture or alter furniture set-up).

If Illness Occurs

A student with known exposure or who begins experiencing illness of Covid-19 should self-isolate and report the illness to Housing Staff immediately.

BACTERIAL MENINGITIS

This information is being provided to all new college students in the state of Texas. Bacterial Meningitis is a serious, potentially deadly disease that can progress extremely fast- so take utmost caution. Bacterial Meningitis is an inflammation of the membranes that surround the brain and spinal cord. The bacteria that cause meningitis also infect the blood. This disease strikes about 3,000 Americans each year, including 100-125 on college campuses, leading to 5-15 deaths among college students every year. There is a treatment, but those who survive may develop severe health problems or disabilities.

What are the Symptoms?

- High fever
- Vomiting
- Confusion and Sleepiness
- Seizures
- Severe Headache
- Light Sensitivity
- Nausea
- Rash or Purple Patches on Skin
- Stiff Neck
- Lethargy

There may be a rash of tiny, red-purple spots caused by bleeding under the skin. These can occur anywhere on the body. *The more symptoms, the higher the risk, so when these symptoms appear seek immediate medical attention.*

How is Bacterial Meningitis Diagnosed?

Diagnosis is made by a medical provider and is usually based on a combination of clinical symptoms and laboratory results from spinal fluid and blood tests. *Early diagnosis and treatment can greatly improve the likelihood of recovery.*

How is the Disease Transmitted?

The disease is transmitted when people exchange saliva (such as kissing or by sharing drinking containers, utensils, cigarettes, toothbrushes, etc.) or come in contact with respiratory or throat secretions.

How do you Increase your Risk of Getting the Disease?

Exposure to saliva by sharing cigarettes, water bottles, eating utensils, food, kissing, etc. Living in close conditions (such as sharing a room/suite in a residence hall or group home).

What are Possible Consequences of the Disease?

- Death (in 8-24 hours from perfectly well to dead)
- Permanent Brain Damage
- Kidney Failure
- Limb Damage (fingers, toes, arms, legs) that requires amputation
- Gangrene
- Coma
- Convulsions
- Hearing Loss, Blindness
- Learning Disability

Can the Disease be Treated?

Antibiotic treatment, if received early, can save lives and chances of recovery are increased; however, permanent disability or death can still occur. Vaccinations are available and should be considered for living in close quarters and college students 25 years or younger. Vaccinations are effective against 4 of the 5 most common bacterial types that cause 70% of the disease in the US (but does not protect against all types of meningitis). Vaccinations take 7-10 days to become effective, with protection lasting 3-5 years. The cost of vaccination varies so check with your health care provider. Vaccination is safe; common side effects are redness and minor pain at injection site for up to two days. Vaccination is available at the Grayson County Health Department.

How Can I Find More Information?

Contact your own health care provider. Contact your local or regional Texas Department of Health office at 903.893.0131 or 515 North Walnut, Sherman. Websites:

<https://www.cdc.gov/meningitis/bacterial.html> or acha.org.

CAMPUS SECURITY & FIRE SAFETY REPORT

Grayson College operates two residence halls on the Main Campus. There are no residence halls on the South Campus. GCPD maintains a fire run report for any fire that occurs in a college residence hall, in the format of a "fire log." This fire log run report is available for review in the campus police office during normal business hours of the College. All residence hall annual fire statistics are reported in a campus public safety brochure and in an attached addendum to the annual crime report and may be located at grayson.edu>Campus Life> [Police and Campus Safety](#). These annual fire statistics include the number and cause of each fire, number of fire deaths and injuries, value of property damaged during fire and the fire drills held each year in the residence halls.

As required by federal law and the Jeanne Clery Act, Grayson College Police Department prepares the Annual Security and Fire Report (ASR) for all employees, students and visitors. The ASR contains information pertinent to those students residing in the residence halls. Information such as crime statistics, fire safety and statistics, whom to report crimes to and many other items are covered in

the ASR. The Report is made available in two ways. A hard copy of the report is available upon request at the College Police Department during normal business hours. A [digital copy of the Report](#) may also be obtained on the College website. As mentioned above, the ASR contains information regarding the number of fires that have occurred within the residence halls. Along with this data, the number of fire drills, value of property damaged and/or deaths and injuries resulting from fires. The ASR also contains data from the three prior consecutive years.

For each residence hall occupant, a Residence Hall Handbook is prepared and distributed, which includes residence hall rules and regulations as well as fire safety information. Included in this Handbook is a description of the fire safety systems for the residence halls that includes smoke alarms in each residence hall room, fire extinguishers and fire alarm pull stations throughout the residence halls common areas. Keep in mind that the alarm pull stations are local alarms only and not on a monitored alarm system. A phone call to 911 will be required to report the alarm.

Possession of appliances in the residence halls is limited to those that may contribute as a fire hazard and are further described in the Residence Hall Handbook. Smoking is also prohibited in the residence halls as well as possession of any object that emits an open flame such as a fragrance candle or burning incense.

Should a fire occur in the residence halls, occupants should follow the evacuation procedures and routes that are outlined in the Residence Hall Handbook and call 911 for a response by the fire department. Once the 911 call is made, the caller will be connected to the dispatch center of the Grayson County Sheriff's Office who will dispatch fire services to the residence hall. A campus public safety officer will also be dispatched by the 911 operator to the scene of the fire to assist occupants at the fire scene and file a report afterwards.

Fire safety information in the form of pamphlets is made available to the residence hall occupants to help prevent fires both in the residence halls and in common areas of the campus. All students and employees are encouraged to review a copy of these pamphlets available in the College Police Department to help prevent fire dangers on campus.

ACTIVE SHOOTER QUICK RESPONSE GUIDE

If the shooter is not in your building, you should lockdown:

- Lock doors if possible
- Barricade doors with ANYTHING
- Turn off lights and other electronics
- Silence cell phones
- Place a note in an exterior window with the number of people in the room, if safe to do so
- One person should call 911 and let them know your location
- Wait until the "all clear" is given by authorities

IF YOU WITNESS AN ACTIVE SHOOTER, AVOID, DENY, DEFEND.

AVOID the situation if it is safe and an exit is available:

- If you are in an area that is not affected, stay where you are and lock the room you are in or make it safe.
- If you can leave the affected area, do so quickly and quietly.
- Get others to follow *if possible*.
- When you are safe, call 911.

If you cannot leave the area safely, DENY entry to the intruder by:

- Locking doors
- Turning off lights
- Silencing phones and other electronics
- Staying away from doors and windows
- Remaining in place until the “all clear” is given by authorities

If you cannot AVOID or DENY entry to the intruder, DEFEND your location by:

- Physical force, using any weapons available such as furniture
- Be aggressive, be loud and be sure of your actions
- Commit to your pre-developed plan of action

When the police get to you:

- Show them your empty hands
- Do what they tell you without delay
- Know that they will not stop for the injured

FIRE & EMERGENCY EVACUATION PROCEDURES

POLICY STATEMENT

Failing to comply with established fire regulations may endanger the safety of all Housing residents. Therefore, it is the policy of Grayson College to require Housing residents to strictly observe fire prevention and emergency evacuation procedures.

The following emergency evacuation procedures apply to all residents and guests and must be followed should smoke and/or fire be detected or the fire alarm be activated.

DEFINITIONS

Primary Escape Route

Emergency exit doors at the end of each hallway.

Secondary Escape Route

Inner common stairwells.

Designated Meeting Place

P10 (located in the parking lot east of Viking Hall) and P20 (located in the parking lot east of Jones Hall).

PRIOR TO EVACUATING THE RESIDENCE HALL ROOM

Place the back of your hand against the door, the knob, or the crack between the door and the door frame on the side with the hinges. If it is hot, stuff a towel or other cloth material at the base of the door to prevent smoke from entering the room. Crawl to the window for escape or to signal for help.

NOTE: If you are two more stories above the ground and are in imminent danger of losing your life with no foreseeable route of escape, **jump only as a last resort.**

If the door is cool, brace yourself against it, turn your face away and open it carefully. If heat and smoke come in, slam the door, making sure it is latched and proceed as above. If no fire, heat or smoke is detected upon checking the door, prepare to evacuate through the nearest unobstructed primary or secondary escape route.

EVACUATION PROCEDURES

- Evacuate the building immediately. If possible, shut the windows and close the room door upon leaving.
- All residents will leave the building by either the primary or secondary escape routes.
- Should a resident not be in the assigned wing when it is time to evacuate, he/she must evacuate with the wing that they are in at the time, and not return to their assigned room or area.
- Upon evacuating, if smoke is encountered, crawl low (12 to 24 inches off the floor) to the nearest unobstructed exit.
- If the general building fire alarm has not been activated at the time of evacuation, activate an alarm by pulling the nearest alarm pull station on your way out of the residence halls.
- The first person out of the primary or secondary escape route should prop the door open for ease of evacuation.
- Once all residents have evacuated, the emergency exit door should be closed, if safely possible.
- NEVER RE-ENTER A BURNING BUILDING or allow anyone else to do so. Once out, stay out and do not re-enter the building until the scene is safe and you are authorized to do so by an on scene public safety official.
- After evacuation, all dormitory residents are required to meet with the Residence Hall Supervisor or other college official at the designated meeting place for their residence hall.
- Residents are further required to remain at the designated meeting place until released by an authorized college official.

DURING EVACUATION

- Do not waste time getting dressed or gathering valuables. You have no time to spare. No possession is worth your life.
- If your clothes catch fire, stop, drop and roll. DO NOT RUN! Cover your face and mouth with your hands for protection from the flames and roll over and over to smother the flames.
- If you view someone else's clothes on fire, tackle or knock the person down and help the person to roll on the ground. If available, throw a blanket or rug over the victim to smother the fire.
- USE YOUR SENSES! If you smell smoke, feel excessive heat, see an actual fire or hear a fire alarm, STAY CALM and THINK! Then take quick, deliberate, but cautious action.

FIRE DRILLS

The Housing Coordinator will schedule a minimum of one fire drill per semester to ensure all residents are acquainted with fire evacuation procedures. All residents are required to participate and may not receive any advance notice of a scheduled fire drill.

COLLEGE RULES & REGULATIONS

The failure of any resident to strictly follow the above procedures may result in a student disciplinary action being brought against the resident, which may include a range of penalties up to and including expulsion from the College.

FIRE RELATED LAW

According to Texas Penal Code 42.06, it is a Class A misdemeanor to initiate a false fire alarm. Class A misdemeanors are punishable by a fine not to exceed \$4,000, confinement in jail for a term not to exceed one year or both such fine and imprisonment. It is also a violation to tamper with fire safety equipment such as fire extinguishers.

EMERGENCY EVACUATION TIPS

- When evacuating, Viking Hall residents should assemble in P10 (located in the parking lot east of Viking Hall) and Jones Hall residents in P20 (located in the parking lot east of Jones Hall).
- Familiarize yourself with this building so that if there is an emergency requiring evacuation, you will know alternate routes for escape in case one or more routes are blocked.
- There are evacuation routes at each end of the residence halls and in the center of the buildings.
- In an emergency evacuation situation, when you leave your room, take your key with you, and close your door.
- At night keep your key in a designated location near your bed so you can find it in the dark.
- Count the number of doorways as you walk or crawl to determine your position in relation to an exit.

JONES HALL EVACUATION PLAN

3rd FLOOR

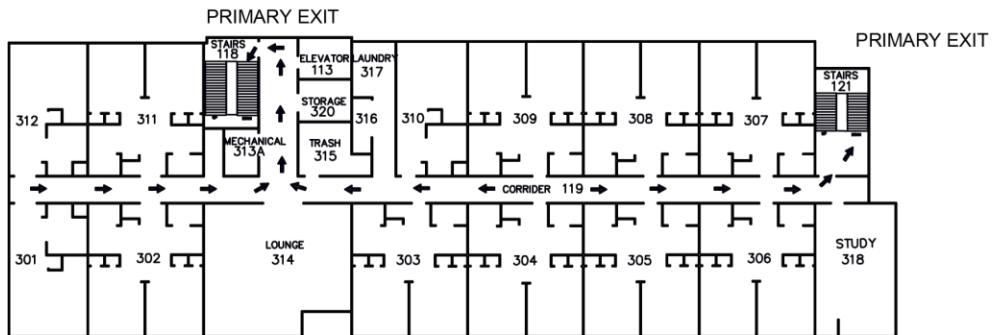

2nd FLOOR

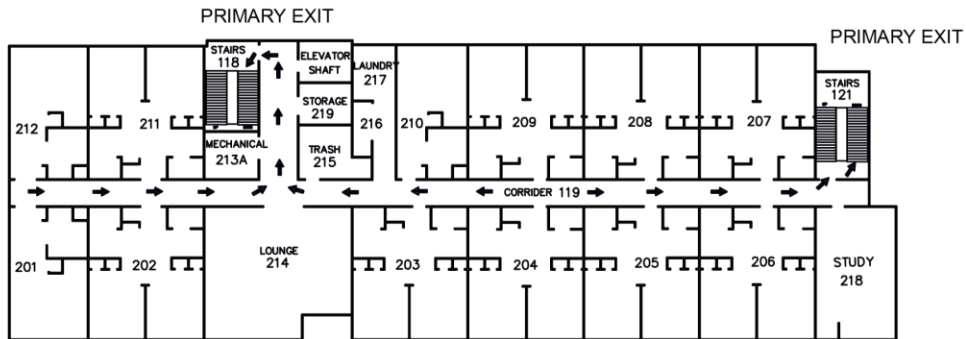

1st FLOOR

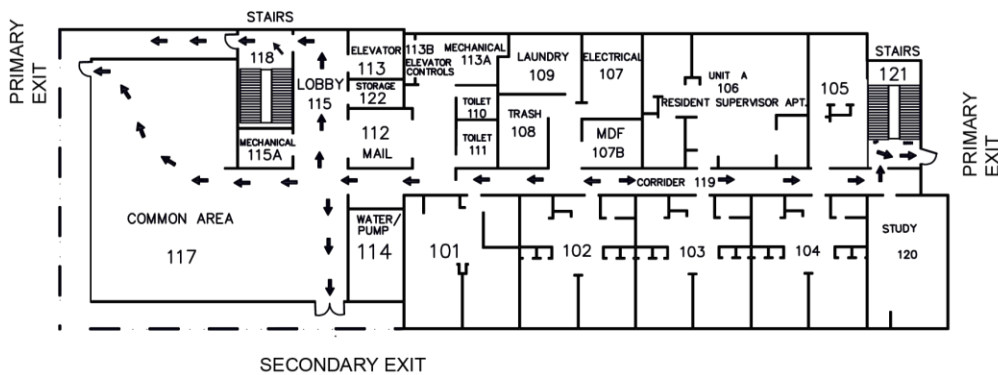

VIKING HALL EVACUATION PLAN

1st Floor

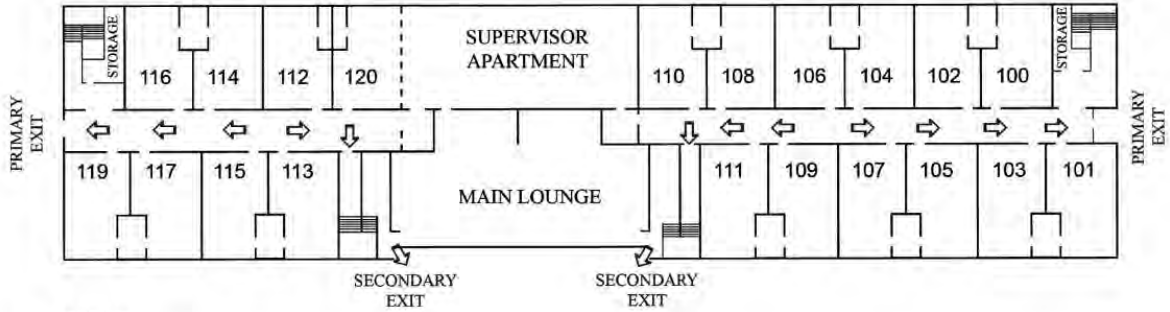

2nd Floor

